

IDEM STAINLESS STEEL IP69K GUARD LOCKING SWITCH KL1-SS

220001

KL1-SS M20 24v LED only

- Solenoid locking
- Provides 4 actuator entry points
- Compact 63mm wide x 143mm long
- 2 lock monitoring safety contacts
- Rotatable head



Product description

The KL1-SS Series Guard Locking switches have a rugged Stainless Steel 316 body and have been developed with a holding force of 1600N to keep medium to large guard doors closed until hazards have been removed.

They are designed to cope with the rigorous applications of the Food Processing, Packaging, Pharmaceutical and Petro-Chemical industries.

They have IP69K enclosure protection (maintained by a double seal lid gasket and seals) and can be high pressure hosed with detergent at high temperature.

They have a low compact body profile with fixing holes on an industry standard 40mm centre to enable easy fitting to new or existing guards (or where replacement of a non locking tongue switch is required).

The head will rotate to provide up to 4 actuator entry positions.

Specifications

Actuator	Not included
Annual usage	8 cycles per hour/24 hours per day/365 days
Approvals	ISO 13849-1, ISO 14119, EN60204-1, EN62061, EN60947-5-1, UL 508
Central Material	Stainless steel 316
Conduit entry	M20
Contact Type	2NC safety contacts, 1NO auxiliary contact (guard open), 1NO auxiliary contact (lock open)
Contacts	2NC 2NO
Head material	Stainless steel 316
Holding force (F1Max)	2000

IP Class	IP69K, IP67
LED Display	LED1 solenoid power
Manual Operation	Standard manual release lid and side
Maximum approach / withdrawal speed	600
Mechanical reliability B10d	2.5 x 10 ⁶ operations at 100mA load
Mounting	2 x M5
MTTFd	356 years
Operating temperature	-25..50°C
PFHd	3.44 x 10 ⁻⁸
PL	e acc. ISO13849-1
Rated insulation voltage	600V ac
SIL	3 acc. EN62061
Solenoid Voltage	24V ac/dc
Thermal current (Ith)	5
Travel for positive opening	10
Utilisation category	AC15, A300, 3 A
Withstand voltage	2500V ac

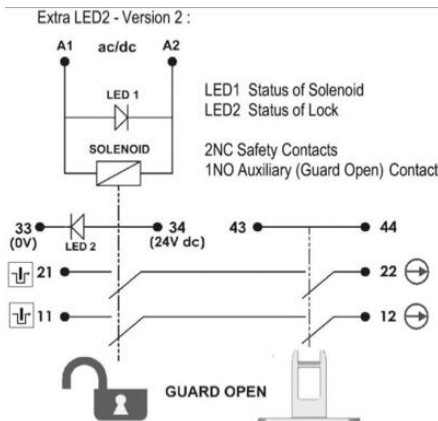
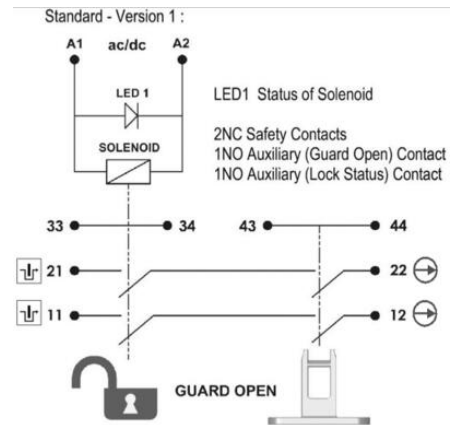
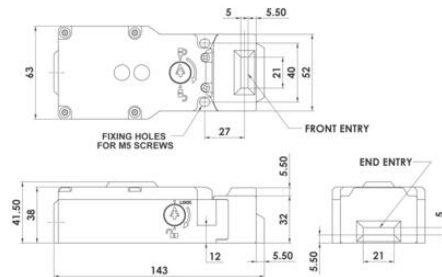
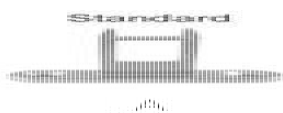

	6.0	5.0	0mm
11/12	Open		
21/22	Open		
33/34			Open
43/44			Open



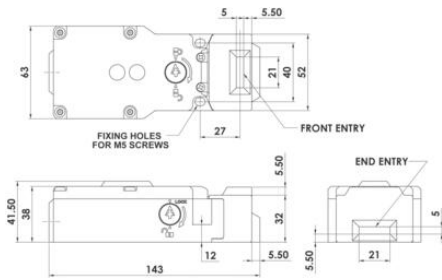

Standard - Version 1 :

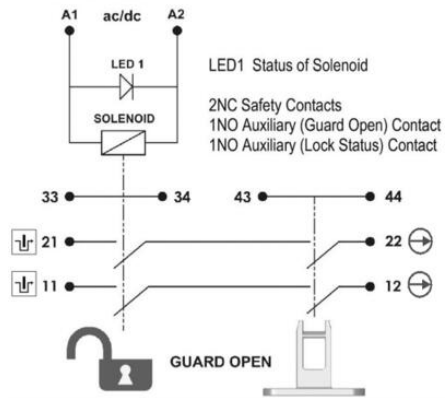

Extra LED2 - Version 2 :

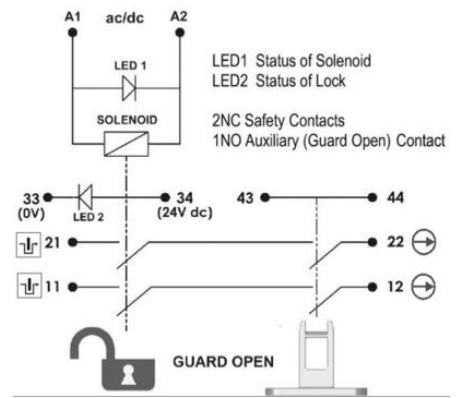

6.0 5.0 0mm

11/12	Open	
21/22	Open	
33/34		Open
43/44		Open